

Distributor Power Cable – 12 AWG

Doc. No. 10600-00068-ASY

REVISIONS			
REV	DESCRIPTION	DATE	APPR
1	Corrected "return" function notation by moving from pin B to pin C.	3 May 2016	EK

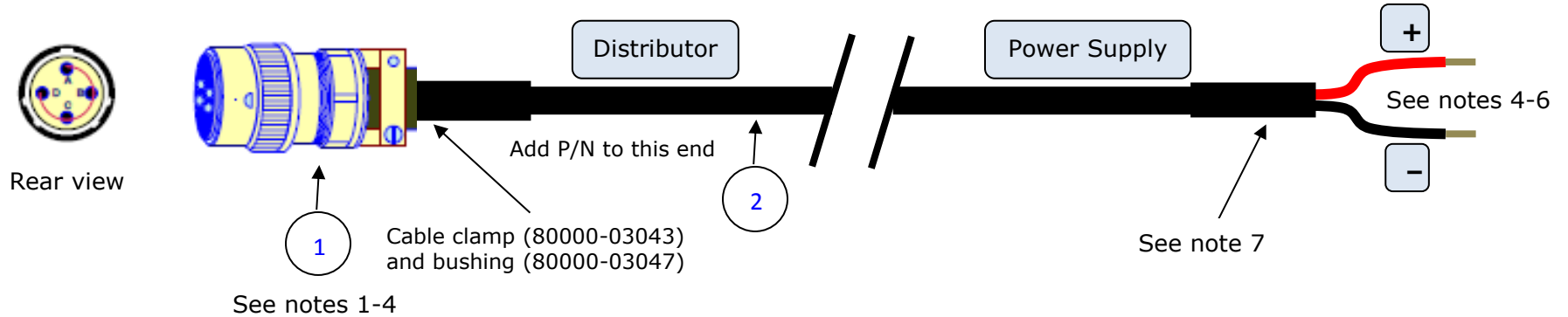

1	2	---
MS3476L14-4S Amphenol Connector (80000-03040) pin number	HW252 01203 (70005-00016) 5 meters wire color	Function
A	RED	+V
B	---	
C	BLACK	return
D	---	
No connection	BLUE	---

Notes:

1. Solder all wires so the insulation is as close as possible to the solder cups.
2. Use RMA or no-clean flux.
3. Use 1/4" length of 1/8" diameter shrink tube on all pins.
4. Cut short the unused wires.
5. Remove insulation (2"), strip and tin (1/4") wires as shown.
6. Label cable ends correctly.
7. Cover edge of cut insulation with 1" length of 1/2" diameter shrink tube.



Copyright © 1998-2016 Diversified Technical Systems, Inc. All rights reserved.

TITLE: Distributor Power Cable – 12 AWG				
PROJECT	DOCUMENT NUMBER	REV	SHEET	SIZE
TDAS	10600-00068-ASY	1	1	
FILE NAME: 10600-00068-ASY.docx				
DATE CREATED	BY	LAST REVISED	BY	APPROVED
8 Jan 2014	EK	3 May 2016	EK	EK