

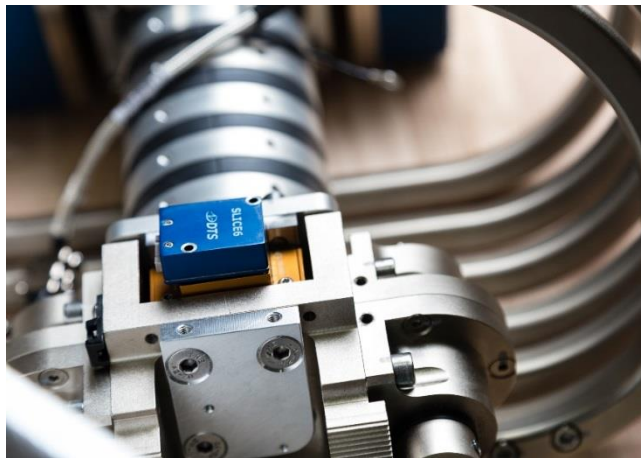

SLICE6 DAS User's Manual

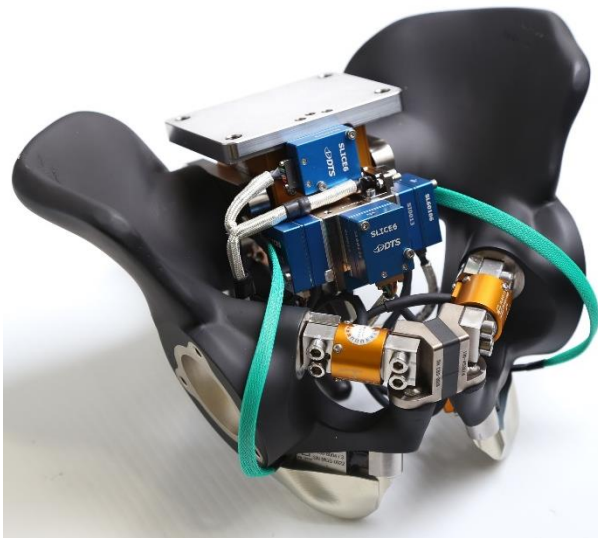

March 2023

Table of Contents

- DTS Support 4**
- Introducing the SLICE6 DAS 5**
- Sensor Interface 5**
 - Supported Sensor Types 6
 - Input Range 6
 - Excitation Sources 6
 - Bridge Completion 7
 - Hardware Filters..... 7
 - Offset Compensation 7
 - Electronic Identification (EID)..... 7
 - Shunt Emulation..... 7
- Communication Bus 7**
 - Communication Method 7
- LED 8**
- Data Memory Size..... 9**
 - Sampling Rates..... 9
 - Circular Buffer Limitations..... 9*
- Basic Care and Handling 10**
 - Shock Rating..... 10
 - Mounting Considerations 10*
 - Thermal Considerations 10
 - SLICE6 DAS Maintenance..... 11
- Power Management..... 11**
 - Power-up and Power-down Procedures 11
- Software 12**
 - Data Collection Concepts..... 12
 - Data Collection Modes 12
 - Circular Buffer Mode..... 12*
 - Recorder Mode 13*
 - Hybrid Recorder Mode..... 13*

- Continuous Recorder Mode 13
- Start Record and Event Initiation 13
- Appendix A: Hardware Specifications..... 15**
 - Connector Information and Pin Assignments 15
 - Mechanical Specifications..... 17
 - Accessories/Support Equipment 18
- Appendix B: Hardware Configuration Specifications 19**
 - Using the *SLICE Network Configuration Utility* 19
- Appendix C: Sensor Interface Wiring Diagrams..... 22**
- Appendix D: Declaration of CE Conformity 30**

DTS Support

SLICE systems are designed to be reliable and simple to operate. Should you need assistance, DTS has support engineers worldwide with extensive product knowledge and crash test experience to help via telephone, e-mail or on-site visits.

The best way to contact a DTS support engineer is to submit a request through the DTS Help Center web portal (support.dtsweb.com). You must be registered (support.dtsweb.com/registration) to submit a request (<https://support.dtsweb.com/hc/en-us/requests/new>). Registration also enables access to additional self-help resources and non-public support information.

This manual supports the following products:

- 13006-90010: SLICE6 DAS Module, 2500 Hz filter
- 13006-90020: SLICE6 DAS Module, 3000 Hz filter
- 13006-90030: SLICE6 HB DAS Module (20 kHz filter)
- 13006-90040: SLICE6 DAS Module, 1500 Hz filter
- 13006-90050: SLICE6 DAS Module, 10 kHz filter
- 13006-90100: SLICE6 DAS Module, 500 Hz filter
- 13006-90120: SLICE6 DAS Module, 1000 Hz filter

Introducing the SLICE6 DAS

The SLICE6 DAS is an ultra-small, low-power, high-shock-rated, data acquisition system ideal for in-dummy and test applications with tight space constraints. Each unit contains a system microprocessor, flash memory for data storage, PTPv2 Ethernet communications support, and 6 analog sensor input channels supporting conventional bridge (piezo-resistive and voltage) sensors, each with isolated excitation, high impedance differential input amplifier, and automatic sensor identification circuits. Units can be interconnected (daisy-chained) via the communication bus connector.

- Sample rates up to 400,000 sps on 6 channels simultaneously.
- Shock rated to 2000 g for dynamic testing environments.
- 6-channel analog sensor interface supports accelerometers, load cells, pressure sensors, strain gage and piezo-resistive bridges, and voltage inputs.
- Thermocouples, 1/4 bridges and other sensor types are supported with adapters as needed.
- LED indicator for system status.
- Ethernet PTPv2 communications (IEEE1588) and sensor ID easily support test set-ups daisy-chaining hundreds of channels.

Connector information, pin assignments and mechanical specifications can be found in Appendix A. Common sensor wiring schematics are shown in Appendix B. Please see your packing list for your hardware's specifications.

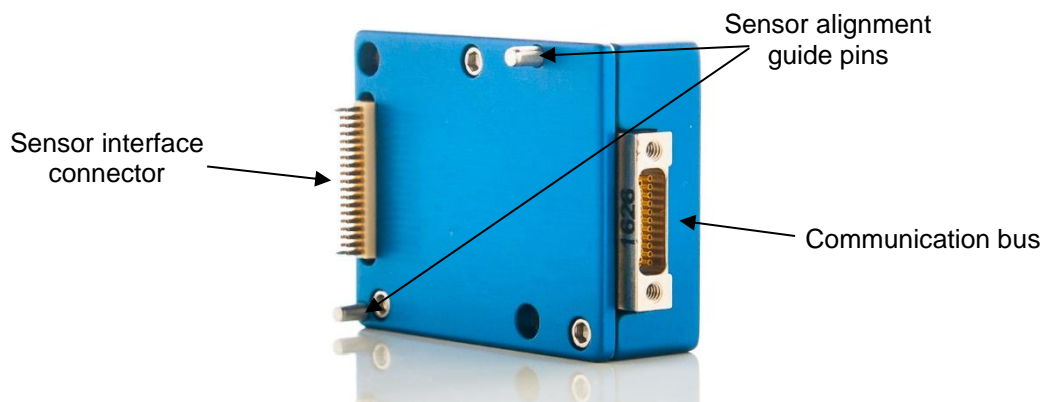

Sensor Interface

The SLICE6 DAS supports 6 sensor measurement channels and is available with a single connector that supports all sensor signals. See Appendix A for sensor connector pin assignments.

Note: The SLICE6 DAS is provided with a connector protector plate assembly attached that protects the sensor interface connector during shipping and storage. *Please retain this assembly for reuse.*

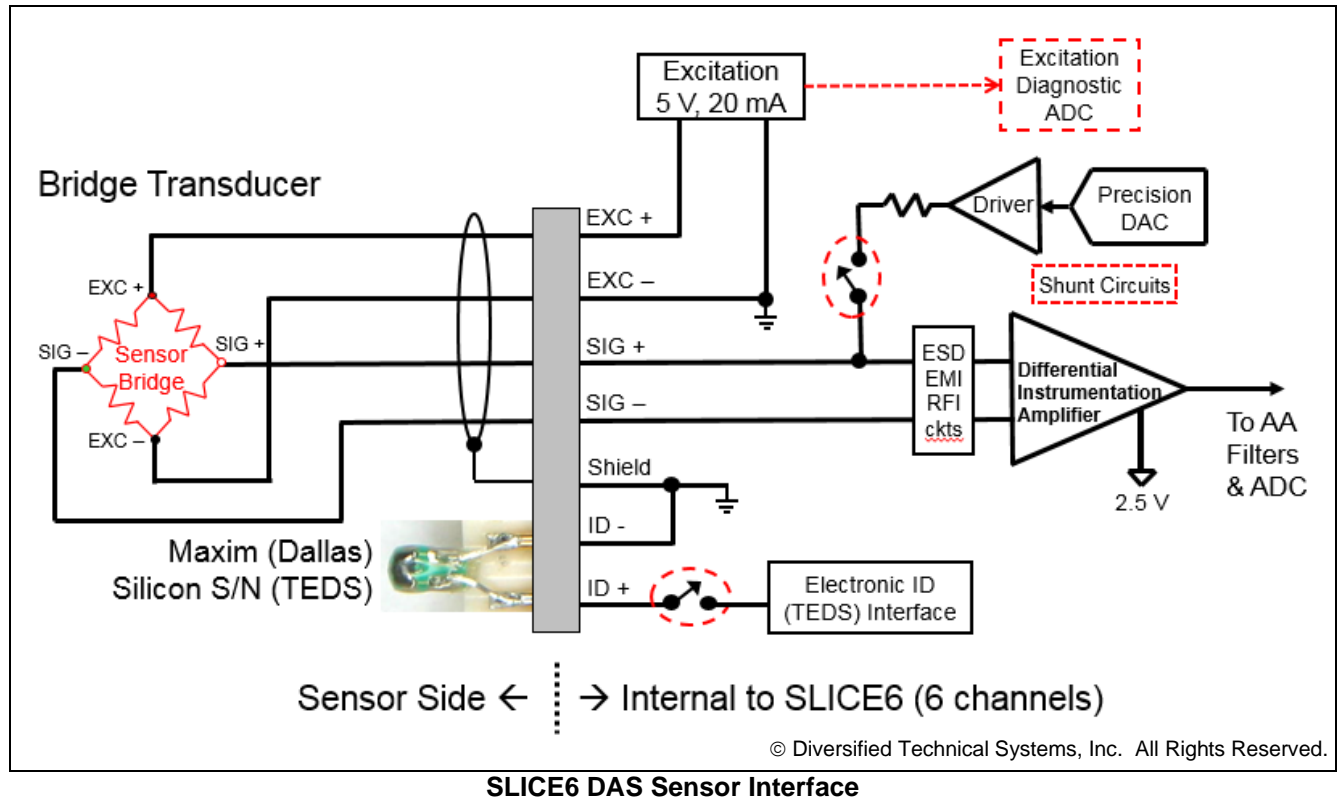

Supported Sensor Types

Supplying 5 V excitation up to 20 mA per channel, the SLICE6 DAS supports many types of sensors including accelerometers, load cells and pressure sensors. The following general sensor types are supported:

- Full- (4-wire) or half-bridge (2- or 3-wire) resistive and piezo-resistive types.
- Voltage input range: 0.1 to 4.9 V; larger ranges supported with range expander cable.
- Conditioned sensors with 5 V excitation and 2.5 V centered signal output.

For additional questions regarding supported sensors, please contact DTS and provide the sensor manufacturer and model number, if available. For specific implementation schematics, see Appendix B.

Input Range

The nominal sensor input range is -2.4 V to +2.5 V (2.5 V center with respect to -Ex) at a gain of 1. At higher gains, the maximum range decreases correspondingly. For example, at a gain of 10, the input range is ± 240 mV. (The software will automatically calculate the gain based on the user-specified input range and other sensor parameters.)

Excitation Sources

The excitation source for each sensor measurement channel is individually regulated. Excitation sources are not turned on until the software initializes the system during diagnostics. The excitation is fixed at 5.0 V.

Bridge Completion

Half-bridge emulation for any channel may be selected via software. Half-bridge transducers should be connected to $\pm Ex$ and -Sig.

Hardware Filters

Each measurement channel has a fixed frequency, 4-pole Butterworth anti-aliasing filter. There are a variety of hardware filters available, including 500 Hz, 1000 Hz, 1500 Hz, 2500 Hz, 3000 Hz, 10 kHz and 20 kHz. Should you have any questions regarding the best filter option for your application, please contact DTS.

Offset Compensation

Each channel can compensate for a sensor offset of up to 100% of the full-range output of a sensor. The sensor offset is measured and the hardware compensation is adjusted during the diagnostic check. Please see the software manual for additional information.

Electronic Identification (EID)

Each measurement channel supports communication with silicon serial number devices manufactured by Dallas Semiconductor/Maxim Integrated Products (model DS2401). When an ID chip is connected to the proper pins on the sensor connector, the software can automatically read these devices and correlate the serial number to channel set-up information stored in the sensor database.

Shunt Emulation

The SLICE6 DAS contains a shunt emulation circuit, effectively eliminating the need for conventional shunt resistors to perform shunt checks. When "Emulation" is chosen as the shunt calibration method, the software injects a precisely-calculated current into the sensor to create an expected deflection of the sensor's output. Expected versus actual deflection are compared to validate that the channel is working properly. Please see the software manual for additional information.

Communication Bus

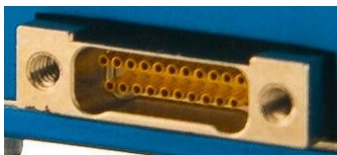

All communications, control signals and input power are provided via the 21-socket, Nano-D communication bus connector. It is also used to interconnect (daisy-chain) multiple units for hundreds of test channels. See Appendix A for pin assignments.

Communication Method











The SLICE6 DAS supports Ethernet PTPv2 communications (IEEE1588). PTP (Precision Timing Protocol) provides standards for precision clock synchronization for measurement and control systems via Ethernet network communications. Timing information is extracted from the network's master clock and used by the SLICE6 DAS to adjust their internal (local) clock, providing precision timing for high channel-count systems with a sampling synchronization better than 10 μs . Communication is enabled after the initialization sequence has completed (15-30 seconds after sufficient power is applied).

LED



The SLICE6 DAS has a single LED indicator that shows system status.

LED behavior is summarized below.

Priority*	Condition	
1	Idle; not connected	 (0.5 Hz)
2	Idle; connected	
3	Communicating; idle or real-time (single flash when command received)	
4	Idle (connected or not connected; low or high power)	 (0.5 Hz)
5	Arming or armed; not recording	
6	Armed; recording	
7	Armed; faulted or triggered	
N/A	Booting bootloader	 (5 Hz)
N/A	Booting firmware	
N/A	Network DHCP initialization (during DHCP negotiation with server; time out after 30 seconds)	 (2 Hz)

* Higher priority will override the lower priority LED state.

Note: There is no post-event indication. The LED transitions automatically based on condition.

Data Memory Size

With 15 GB of flash memory available for data storage, the SLICE6 DAS can record ~52 minutes of data at the maximum sampling rate (6 channels at 400 ksp/s). Since the recording capacity is very large, it is generally best to limit sampling rates and event durations to the minimum necessary to avoid large and cumbersome data files. Large files take longer to download and may also be time-consuming to post-process or difficult to share. Use of the Region of Interest (ROI) download can save a great deal of time if implemented properly.

Sampling Rates

User-selectable sampling rates are available from 2,000 sps to 400,000 sps.

# of Channels*	Maximum Sampling Rate (per channel)
6	400,000 samples per second (sps)

* All channels are recorded even if they are not programmed.

With 15 GB available for data storage, there are 7,500 M samples available (1 sample = 2 bytes). To determine the maximum recording time, divide the number of samples by the product of the sampling rate and the number of channels.

$$\frac{7,500,000,000}{\text{Sampling rate (sps)} \times \text{\# of channels}} = \text{\# of seconds}$$

Example: 6 channels of data at 400,000 sps

$$\frac{7,500,000,000}{400,000 \times 6} = 3,125 \text{ sec (52 minutes)}$$

Circular Buffer Limitations

Due to the nature of flash memory, the system cannot be armed in *Circular Buffer* mode indefinitely. To determine the maximum time available, use the equation below:

$$0.8 * \text{recording time} = \text{maximum time available in Circular Buffer mode}$$

Example: $0.8 * 3,125 \text{ sec} = 2500 \text{ sec (41 minutes)}$

In this example, the test must occur within 41 minutes, after which time the unit stops recording data.

Basic Care and Handling

SLICE6 systems are precision devices designed to operate reliably in dynamic testing environments. Though resistant to many environmental conditions, care should be taken not to subject the units to harsh chemicals, submerge it in water, or drop it onto any hard surface.

WARNING:

Electronic equipment dropped from desk height onto a solid floor may experience up to 10,000 g. Under these conditions, damage to the exterior and/or interior of the unit is likely.

Your SLICE6 DAS is supplied with calibration data from the factory. DTS recommends annual recalibration to ensure the unit is performing within factory specifications. The DAS is not user-serviceable and should be returned to the factory for service or repair.

The SLICE6 DAS is provided with a connector protector plate assembly (P/N 89000-22530-R) attached that protects the sensor interface connector. *Please retain this assembly for reuse.* When the DAS is not in use or if shipping is required, reattach the sensor interface connector protector plate assembly provided with your unit. DTS recommends that you store and ship the unit using the padded container originally provided with your system.

Shock Rating

Each SLICE6 DAS is rated for 500 g, 3 ms or 2000 g, 0.8 ms half-sine duration, in all axes.

Mounting Considerations

SLICE6 equipment should be bolted securely to the test vehicle or dynamic testing device to provide the best shock protection. Mounting methods and hardware selection should be carefully calculated to withstand expected shock loading and facilitate proper grounding. Check bolt tightness periodically to ensure that 1) the unit is securely fastened to the baseplate, and 2) the baseplate is securely fastened to the testing platform.

DTS strongly recommends that all equipment be properly grounded to minimize any risk of data noise due to high-current transients. The test vehicle or dynamic testing device should be connected to earth ground. SLICE6 equipment should be grounded to each other and bolted to the test vehicle. DTS recommends checking continuity between the enclosures of each unit to confirm resistance readings of <1 ohm.

Thermal Considerations

The SLICE6 DAS is a low power device and it is unlikely that self-heating will be an issue in real-world testing if proper mounting methods are observed. Never mount the unit to a thermally non-conductive surface like wood or plastic. ALWAYS use SLICE6 DAS with a heat sink. If you are not mounting the system to a structure that will serve this purpose, DTS offers a heat sink for use with the SLICE6 DAS (see Appendix A). Should you have any questions about using SLICE in your environment, please contact DTS.

SLICE6 DAS Maintenance

Periodically inspect 1) the connector contacts for proper alignment or other damage, and 2) the sealing gasket surrounding the sensor interface connector and adjust if necessary. A picture of the sensor interface connector and a properly installed gasket (P/N 89100-19880-R) is shown below.

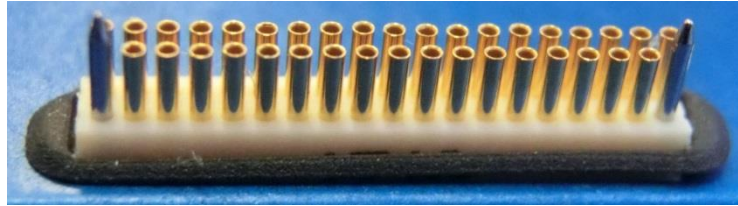

Power Management

A good power source is of paramount importance. SLICE6 DAS should be powered from a SLICE6 Distributor. (One SLICE6 Distributor can support up to 4 SLICE6 DAS chains of up to 10 DAS per chain for a total of 40 DAS or 240 channels.) Be sure to consider any power drop due to cable length.

Input Voltage	Power Consumption			
	Deep Sleep	Idle (On)	Data Download (On)	Data Collection (On and Armed)
9-15 VDC ¹	12 mW	840 mW	900 mW	2.5 W

The SLICE6 DAS does not contain an internal battery and must be connected to external power at all times for operation. Without external power applied, the SLICE6 DAS is in a power off state.

With power applied, the DAS is either in deep sleep or on. If the ON signal is absent or removed, the DAS enters deep sleep, the lowest power consumption state. With the ON signal applied, power consumption is 840 mW-2.5 W, depending largely on the connected sensor load and the unarmed/armed state of the unit.

Power-up and Power-down Procedures

When sufficient power is applied, the SLICE6 DAS will power up (on, idle and communications enabled) if an ON signal is present. If an ON signal is absent, the unit will initiate a limited power up sequence and immediately enter deep sleep. Power up (On state) occurs within 15-30 seconds (static IP or DHCP, respectively), after which communication is enabled. The unit enters deep sleep ~2 seconds after the ON signal is removed.

Power down of the DAS is immediate upon removal of external power. Wait ~30 seconds before reinitializing the DAS.

¹ Commercially-available 9 V batteries should not be used to power the SLICE6 DAS.

Software

Both SLICEWare and DataPRO software applications support the SLICE6 DAS.

Minimum PC Specifications

Parameter	SLICEWare (version 1.9 and higher)	DataPRO (version 1.10 and higher)
Operating system	Windows 7, 8 and 10; 32- and 64-bit	Windows 7 and later; 32- and 64-bit .NET Runtime version 4.5.2 MS Access ODBC drivers*
Processor	1 GHz	i5 minimum; i7 recommended
RAM	2 GB**	8 GB minimum; 16 GB recommended**
Hard drive disk space	100 MB + more for test data	1 GB + more for test data
Screen resolution	1024 x 768	1366 x 768 minimum; 1920 x 1080 recommended

* Usually included with Microsoft Office

** More RAM is important for high channel counts and longer/higher sample rates

Additionally, DTS recommends a network that supports gigabit Ethernet (GbE).

Data Collection Concepts

The discussion below provides a general introduction to data collection. Please see the software manual for a detailed discussion and implementation specifics.

The SLICE6 DAS is a standalone data logger. Once the system is armed, the PC can be disconnected if desired. After receiving a Start Record or Event signal, SLICE autonomously collects data, storing it to flash memory with no user interaction. After the test, the user reconnects the PC to download the data.

There is also a real-time mode in the control software that allows the user to check channel inputs on an oscilloscope-looking screen. (This data can be logged.)

Data Collection Modes

The SLICE6 DAS supports 4 data collection modes: Circular Buffer, Recorder, Hybrid Recorder, and Continuous Recorder. (Note: The software cannot simultaneously display the data while the system is recording.)

Circular Buffer Mode

Using Circular Buffer mode, the user can program the SLICE6 DAS to record pre- and post-Event data. Time Zero (T=0) is marked when the Event signal is received.

Due to the nature of flash memory, the system cannot be armed in Circular Buffer mode indefinitely. Please see page 9 for information on how to calculate data storage duration when using Circular Buffer mode.

Recorder Mode

Data collection begins when a Start Record signal is received and continues for the time specified in the test set-up. If an Event signal is received sometime after the Start Record signal, this is marked as T=0.

Hybrid Recorder Mode

Data collection begins when a Start Record signal is received and continues until the unit receives an Event signal. The unit then records for the post-Event time specified by the user. The Event signal marks the T=0 point and all data recorded is available for download.

Continuous Recorder Mode

Data collection begins when a Start Record signal is received and continues until the Start Record signal is released. The unit will then re-arm for another event. The LEDs on the unit will flash blue slowly then rapidly, and then the status LED will become solid blue, indicating the unit is fully armed. The unit will continue to record new events until it records the number of events specified by the user. If an Event signal is received after the unit has re-armed, the unit will disarm and no longer attempt to re-arm.

NOTE:

An event or trigger signal applied anywhere in the SLICE6 DAS chain is distributed throughout the DAS chain and forwarded to the SLICE6 Distributor, but is NOT exported outside the SLICE6 Distributor. This also applies to level trigger.

Start Record and Event Initiation

The SLICE6 DAS supports multiple methods of initiating Start Record and Event signals. Typically, Start Record and Event are initiated via an external hardware interface that provides a discrete contact closure (CC) signal to initiate recording (Recorder mode) or mark T=0 (Circular Buffer mode).

All SLICE6 DAS data collection modes support multi-event arming. A unit armed in a multiple-event mode will re-arm when an event completes. The unit will stop re-arming when the number of events specified by the user has been recorded.

SLICE6 DAS can be placed in an auto-arm mode that will cause the unit to arm automatically when the power is cycled. This available with any available data collection mode.

Additionally, Circular Buffer mode supports level triggering. This method continuously samples the incoming data and begins data collection if the data is above or below predefined levels. For example, it might be useful to begin data collection when a certain accelerometer

experiences a force above 200 g. Using level trigger and Circular Buffer mode, SLICE6 DAS can support this or any level-trigger signal on any channel.

CAUTION:

Level trigger is NOT recommended when SLICE6 DAS is used for in-dummy testing.

Finally, if the SLICE6 DAS remains connected to the PC during data collection, the control software can be used to initiate data collection.

The table below summarizes the data collection modes and event/triggering options.

	Supports T=0 Start Record	T=0 methods supported	Data record window
Circular Buffer	Yes	Hardware (CC), software (PC) or level trigger	User-defined pre- and post- T=0 durations
Recorder	Yes	Hardware (CC), software (PC) or level trigger	User-defined duration after T=0
Hybrid Recorder	Yes	Hardware (CC), software (PC) or level trigger	User-defined post-Event duration
Continuous Recorder	Yes	Hardware (CC), software (PC), or level trigger	User-defined duration after T=0, with recording multiple events possible

Appendix A: Hardware Specifications

Connector Information and Pin Assignments

Communication Bus Connector
(Omnetics A29100-021)

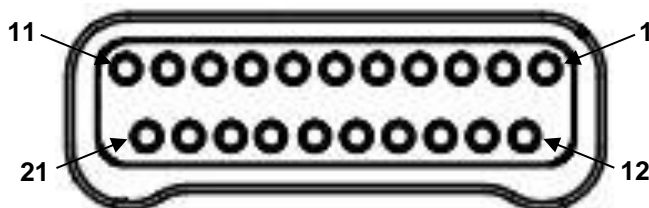

(looking into the connector)

Pin	Function
1	/ON (contact closure input to ground)
2	/START (contact closure input to ground)
3	/EVENT (contact closure input to ground)
4	Status output (5 V via 10K with respect to ground)
5	No connection
6	Ground
7	VDC input
8	Ground
9	VDC input
10	Ground
11	VDC input
12	Ethernet Rx1 (-)
13	Ethernet Rx1 (+)
14	Ethernet Tx1 (-)
15	Ethernet Tx1 (+)
16	Ground
17	Ground
18	Ethernet Rx2 (-)
19	Ethernet Rx2 (+)
20	Ethernet Tx2 (-)
21	Ethernet Tx2 (+)

Sensor Interface Connector
(Omnetics A79047-001)

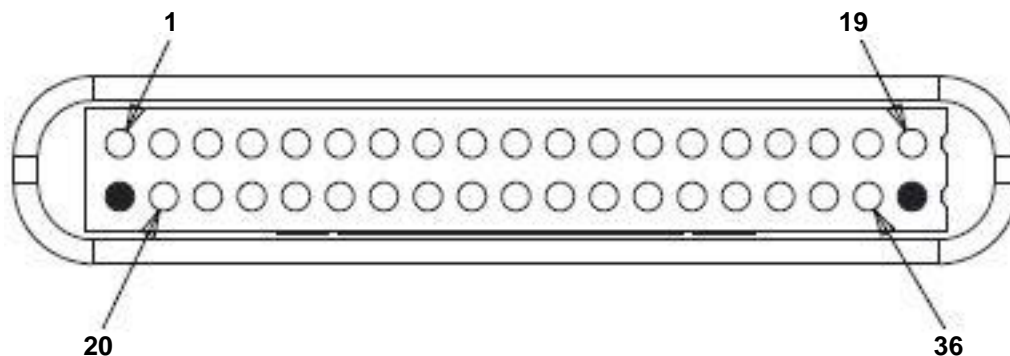

(looking into the connector)

Suggested mating connector P/N:
Omnetics A79046-x01 (DTS P/N 80000-04063(-R))

Pin	Function
1	Ground
2	+Ex (Ch 4)
3	+Sig (Ch 4)
4	-Sig (Ch 4)
5	-Ex (Ch 4)
6	+Ex (Ch 1)
7	+Sig (Ch 1)
8	-Sig (Ch 1)
9	-Ex (Ch 1)
10	+ID (Ch 4)
11	-ID (Ch 4, 5, 6)
12	+ID (Ch 1)
13	-ID (Ch 1, 2, 3)
14	+Ex (Ch 5)
15	+Sig (Ch 5)
16	-Sig (Ch 5)
17	-Ex (Ch 5)
18	+Ex (Ch 2)

Pin	Function
19	Ground
20	+Sig (Ch 2)
21	-Sig (Ch 2)
22	-Ex (Ch 2)
23	+ID (Ch 5)
24	+ID (Ch 2)
25	+Ex (Ch 6)
26	+Sig (Ch 6)
27	-Sig (Ch 6)
28	-Ex (Ch 6)
29	+Ex (Ch 3)
30	+Sig (Ch 3)
31	-Sig (Ch 3)
32	-Ex (Ch 3)
33	+ID (Ch 6)
34	+ID (Ch 3)
35	Reserved
36	Ground

INTELLECTUAL PROPERTY STATEMENT
 This drawing contains information that is the property of Diversified Technical Systems, Inc. (DTS). All copyright, patent, and ownership rights are retained. This information shall not be disclosed, reproduced in whole or in part, or used for manufacture without prior written consent from DTS.

RoHS
 Manufacture/fabricate to meet the EU RoHS Directive 2011/65/EU and RoHS Annex II phthalates

REV	ZONE	DESCRIPTION	DATE	BY
2		P/N, DRAWING FORMAT	2017-08-28	GN
3		DOWEL LENGTH, PAGE 2 TOLERANCES NOTED	2018-03-05	GN
4		MOVED SERIAL NUMBER ABOVE CONNECTOR	2020-01-22	AH
5		ADDED "GROUND" TO PIN 1 AND 19 ON CHART	2023-03-16	JC

NOTES:

1. MASS: 15 GRAMS ±3 GRAMS
2. SLICE6 SENSOR CONNECTOR: OMNETICS P/N A79047-001 (NSD-36-DD-GS)
 MATES WITH: OMNETICS P/N A79046-001 (NPD-36-DD-GS)
3. SLICE6 CHAIN CONNECTOR: OMNETICS P/N A29100-021 (MNSO-21-AA-N-ETH-M)

SENSOR CONNECTOR PIN ASSIGNMENTS

Pin	Signal
1	GROUND
2	+EXCIT-CH4
3	+SIG-CH4
4	-SIG-CH4
5	-EXCIT-CH4
6	+EXCIT-CH1
7	+SIG-CH1
8	-SIG-CH1
9	-EXCIT-CH1
10	+ID-CH4
11	-ID-CH4,5,6
12	+ID-CH1
13	-ID-CH1,2,3
14	+EXCIT-CH5
15	+SIG-CH5
16	-SIG-CH5
17	-EXCIT-CH5
18	+EXCIT-CH2
19	GROUND
20	+SIG-CH2
21	-SIG-CH2
22	-EXCIT-CH2
23	+ID-CH5
24	+ID-CH2
25	+EXCIT-CH6
26	+SIG-CH6
27	-SIG-CH6
28	-EXCIT-CH6
29	+EXCIT-CH3
30	+SIG-CH3
31	-SIG-CH3
32	-EXCIT-CH3
33	+ID-CH6
34	+ID-CH3
35	TEMP-VDC
36	Earth (GND)

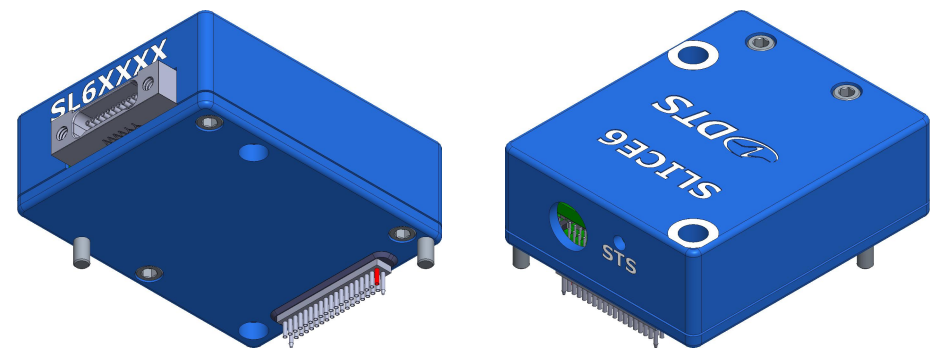
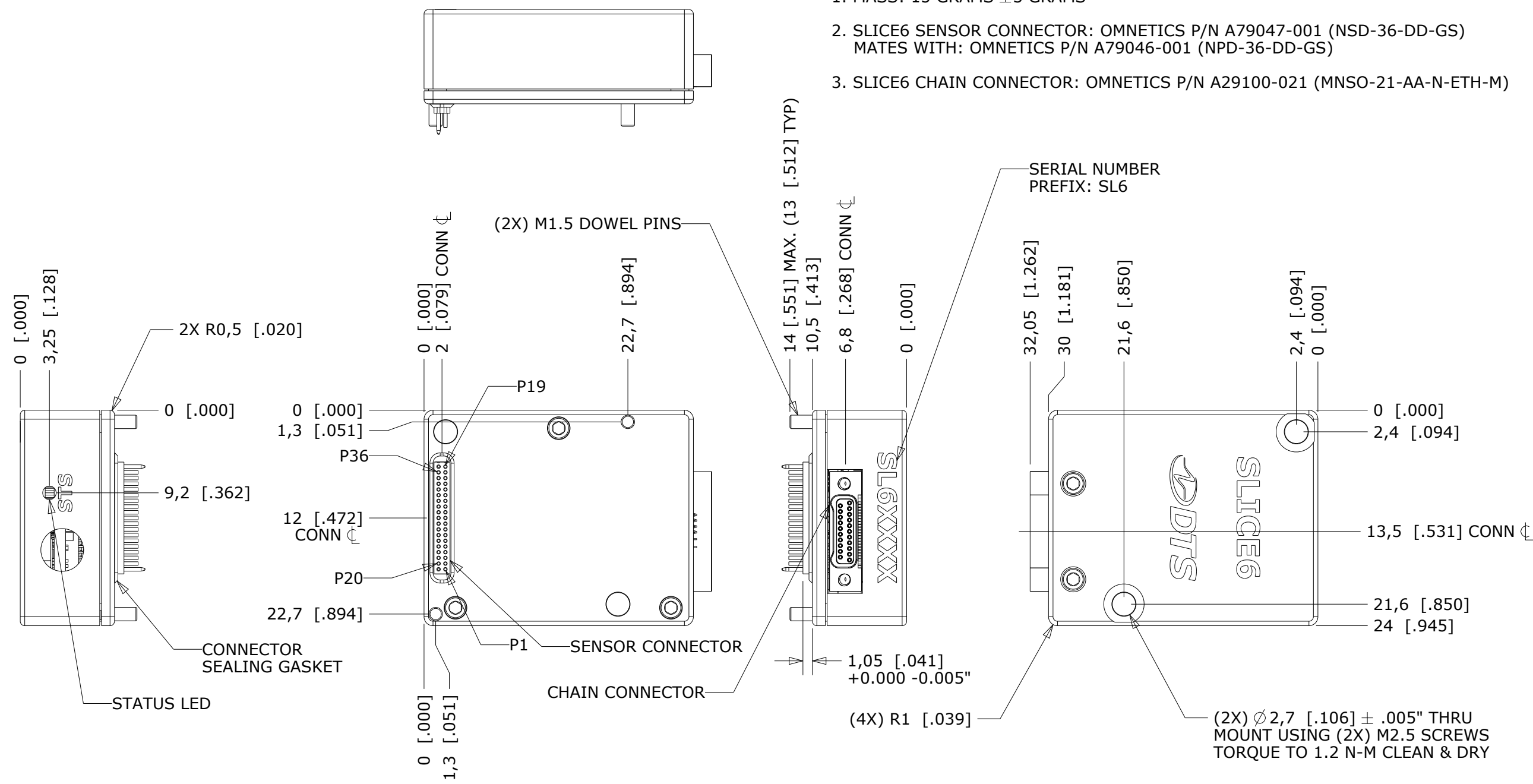

SEAL BEACH, CA 90740 562-493-0158 www.dtsweb.com	DESCRIPTION:		SLICE6 DAS, MOUNTING DRAWING	
	MATERIAL:	DTS P/N:		REV:
6061-T6 ALUMINUM HOUSING W/ BLUE ANODIZE			5	
UNLESS OTHERWISE SPECIFIED:	DRAWN:		G NEWTON	
UNITS = MM [INCH] DIMENSIONAL TOLERANCES ±.254 [0.010"] INTERPRET PER ASME Y14.5. DO NOT SCALE.	DATE:	SIZE:	SCALE:	SHEET:
	2016-09-20	B	2:1	1 OF 2

Accessories/Support Equipment

- 13006-90060: SLICE6 Sensor Interface 2.0
- 13006-90070: SLICE6 Sensor Connector Kit, 1-Channel
- 13006-90080: SLICE6 Sensor Connector Kit, 2-Channel
- 13006-90090: SLICE6 Sensor Connector Kit, 3-Channel
- 13006-90110: SLICE6 1 Ch Sensor Cable Assembly (+ ID, pigtails; 1 ft)
- 13006-90320: SLICE6 Distributor (18-36 V input range)
- 13006-90321: SLICE6 Distributor (13-36 V input range)
- 13006-90420: SLICE6 Distributor (Gen2)
- 80000-04090: Conn assy; 21-pin plug to pigtails, 30 AWG, 18" (mates with comm bus)
- 89000-22530-R: SLICE6 DAS, connector protector plate assembly
(includes 89100-22530-R and 2 each of 93000-S0098-R)
- 89100-22530-R: SLICE6 DAS, connector protector plate
- 89100-19880-R: SLICE6 DAS sealing gasket
- 89100-14480-R: Heat sink, SLICE MICRO/NANO/SLICE6; base plate
- 93000-S0098-R: Screw, SHC, 18-8; M2.5 x 14 mm, 0.45 mm pitch
(2 required for use with 89100-22530-R)

Appendix B: Hardware Configuration Specifications

SLICE6 DAS are typically delivered with a default IP address as follows:

IP address	192.168.1.x where x is determined based on the last two digits of the S/N: x = 10 for S/Ns with 00 or 10; x = 1-9 for S/Ns 01-09, respectively; x = 11-99 for S/Ns 11-99, respectively
Netmask	255.255.255.0

The calibration data for your equipment identifies the IP address as shipped from the factory. If the calibration data is not available, try using the default address described in the table above.

If you need information on the specifics of your equipment, please submit a request through the DTS Help Center web portal (support.dtsweb.com) and include the serial number(s) of the equipment and parameters you are asking about.

Using the *SLICE Network Configuration Utility*

The *SLICE Network Configuration Utility* (available from the DTS Help Center) can be used to view or change the unit's IP address.

Use of the utility requires a network that supports multicast and the workstation running the utility must also allow it. Confirm that:

- The PC's Ethernet properties are not using anything that can block multicast; e.g., *DNE LightWeight Filter*.
- The Windows Firewall will allow multicast traffic.
- Any third-party anti-virus software will allow multicast traffic.

1. Open the *SLICE Network Configuration Utility*.



- The software will immediately look for all attached devices and list them in the table. (You may also click to refresh the list.)

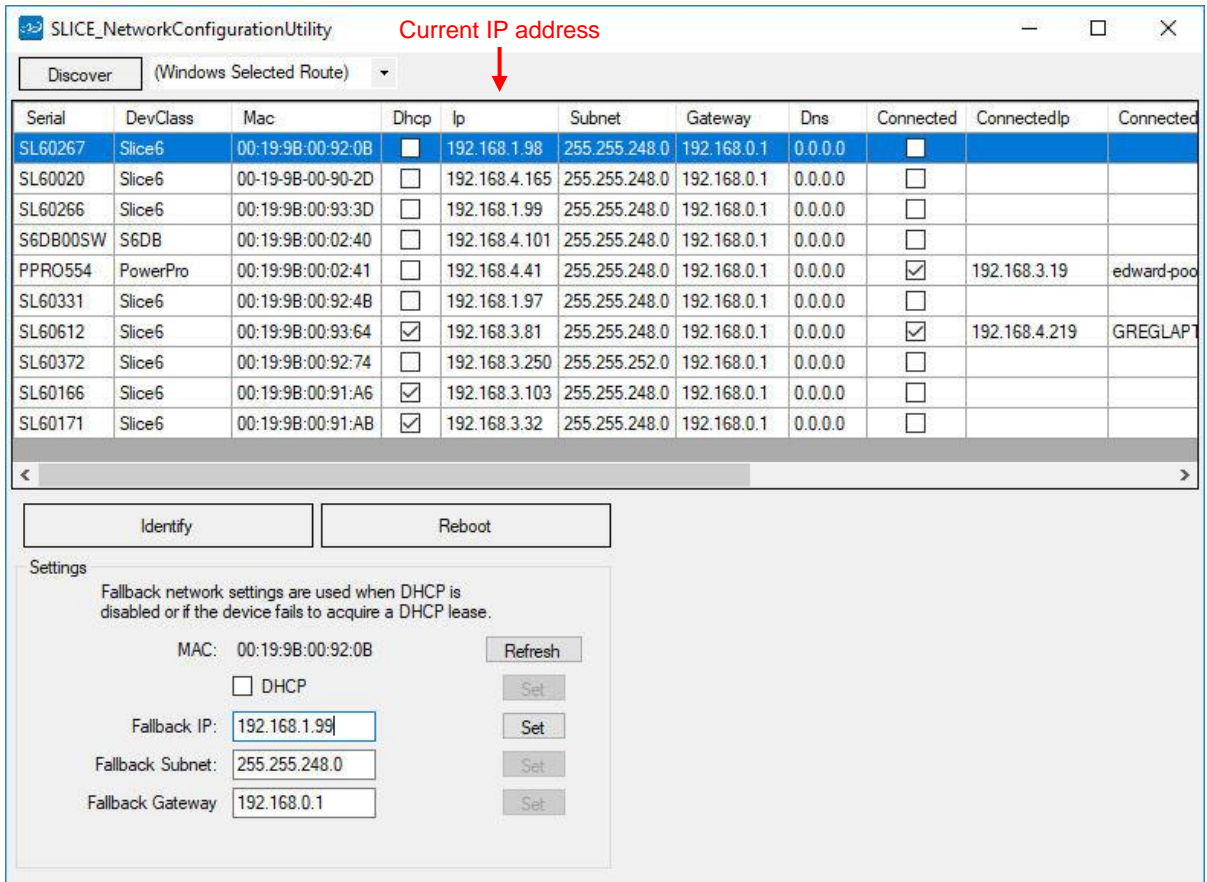

Note: Clicking on for any selected device will cause the unit's LED to flash.

- Select the SLICE6 device from the list. (A SLICE6 DAS is selected in the image above.) The device Settings are shown at the bottom of the window. The current IP address may or may not match the fallback IP address, depending on whether DHCP is selected.

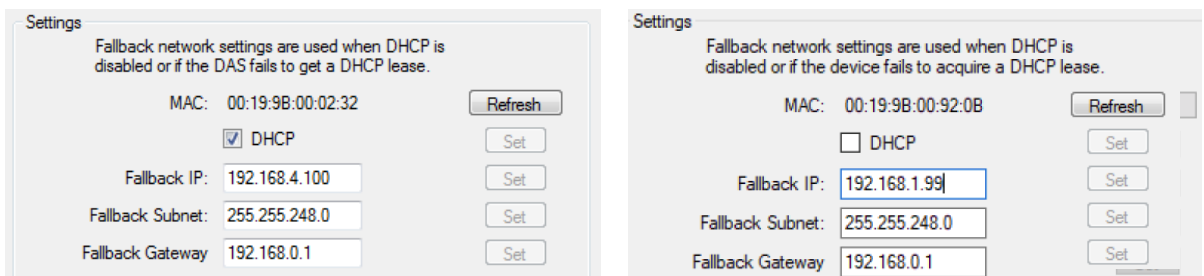

4. To enable DHCP, select the check box then select **Set** . Proceed to step 7.

Settings
Fallback network settings are used when DHCP is disabled or if the device fails to acquire a DHCP lease.

MAC: 00:19:9B:00:90:06 **Refresh**

DHCP **Set**

5. To disable DHCP and manually enter IP address and other information, unselect the check box.

Settings
Fallback network settings are used when DHCP is disabled or if the device fails to acquire a DHCP lease.

MAC: 00:19:9B:00:92:0B **Refresh**

DHCP **Set**

6. Enter the new parameters and select **Set** for each item updated. (Note: The MAC address is not user configurable.)

Settings
Fallback network settings are used when DHCP is disabled or if the device fails to acquire a DHCP lease.

MAC: 00:19:9B:00:92:0B **Refresh**

DHCP **Set**

Fallback IP: 192.168.6.102 **Set**

Fallback Subnet: 255.255.255.0 **Set**

Fallback Gateway: 192.168.0.254 **Set**

7. Select **Refresh** to view the settings (optional), then **Reboot** the device.

Identify **Reboot**

Settings
Fallback network settings are used when DHCP is disabled or if the device fails to acquire a DHCP lease.

MAC: 00:19:9B:00:92:0B **Refresh**

DHCP **Set**

Appendix C: Sensor Interface Wiring Diagrams

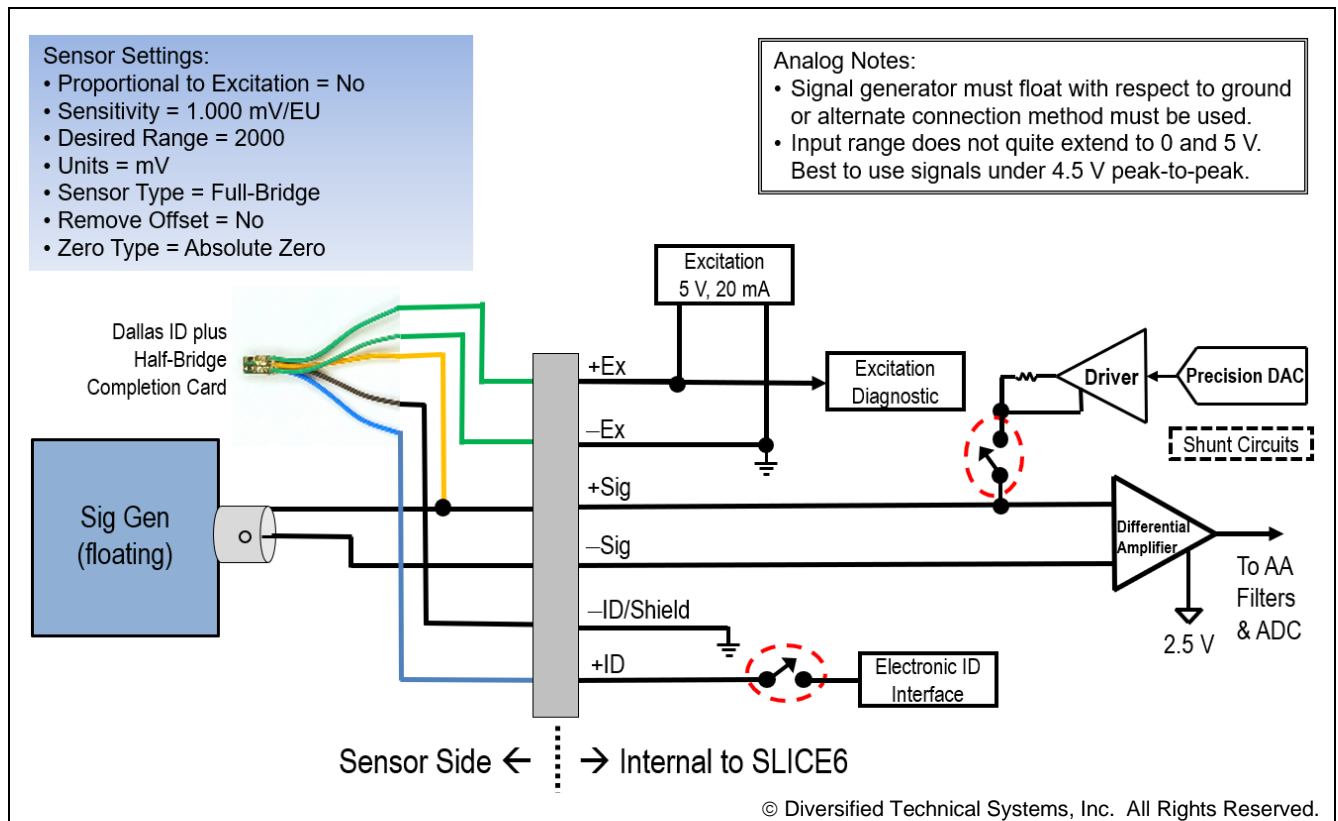
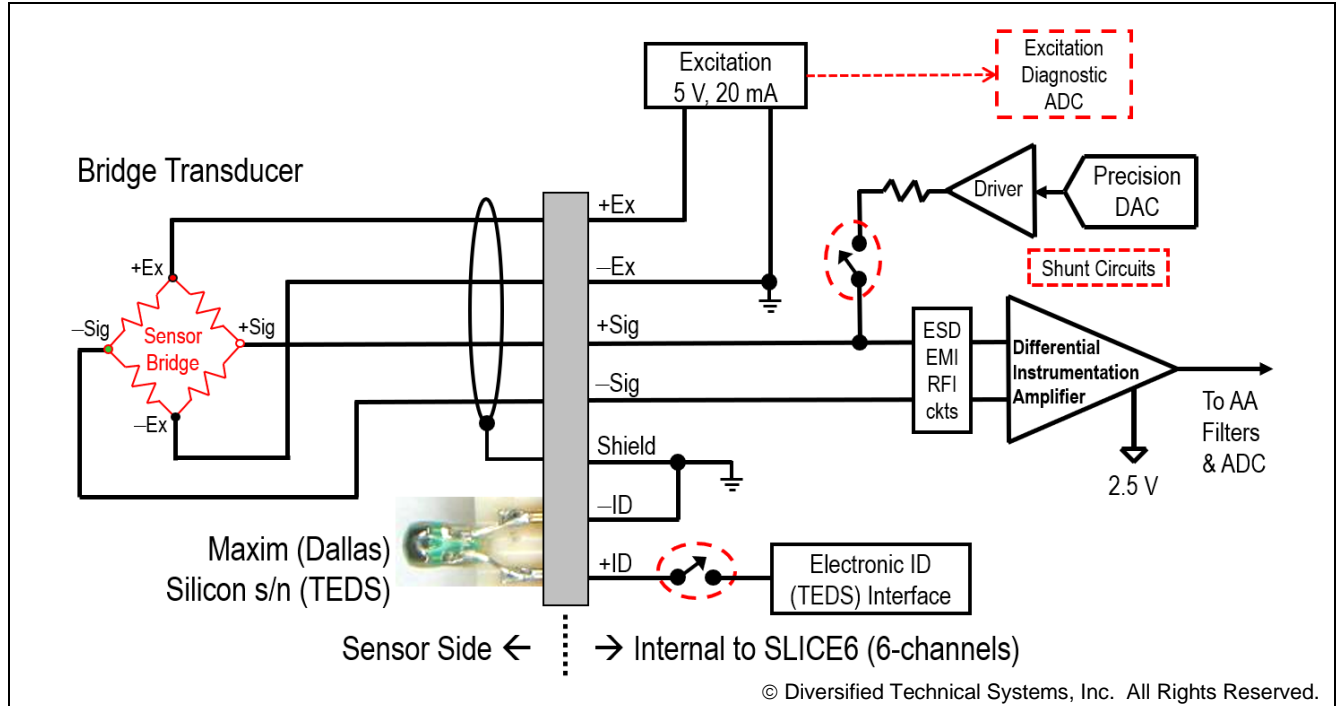

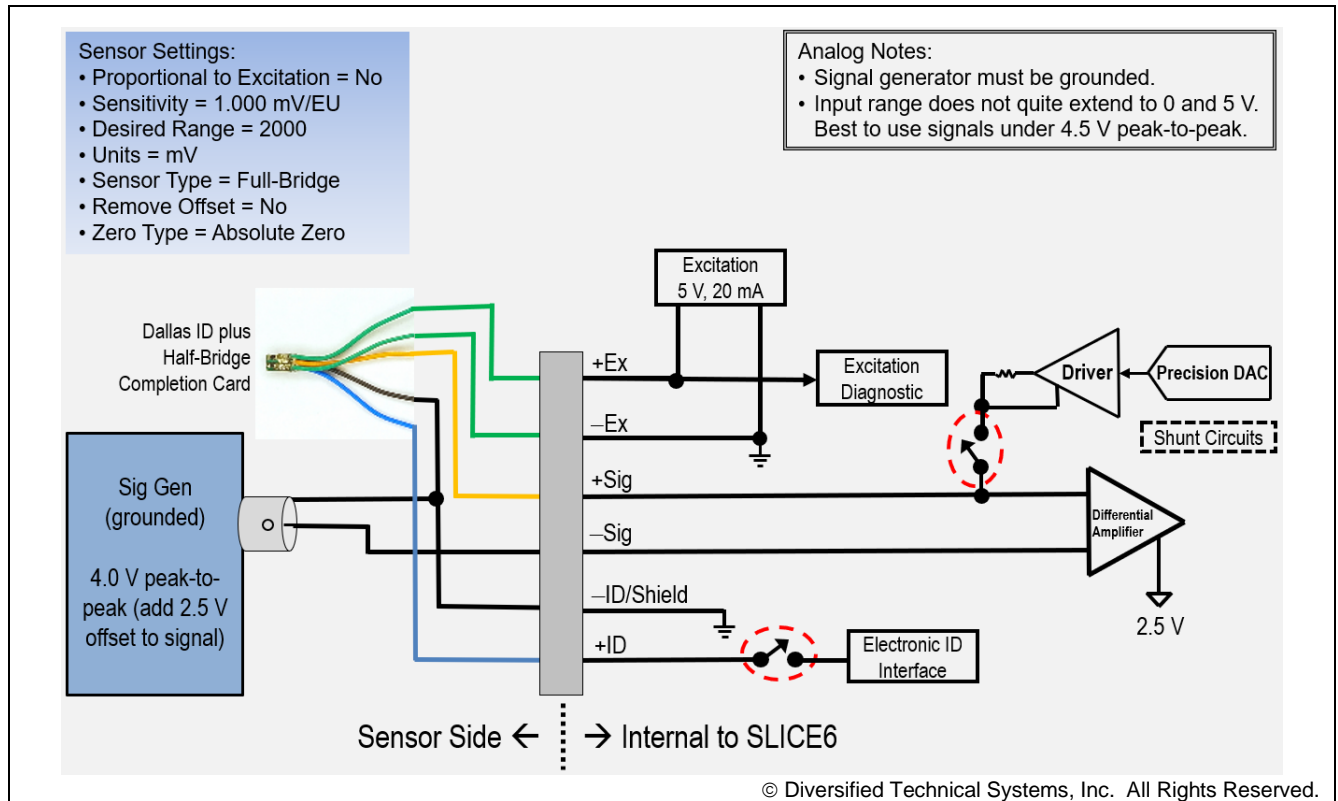

Signal Generator (grounded)

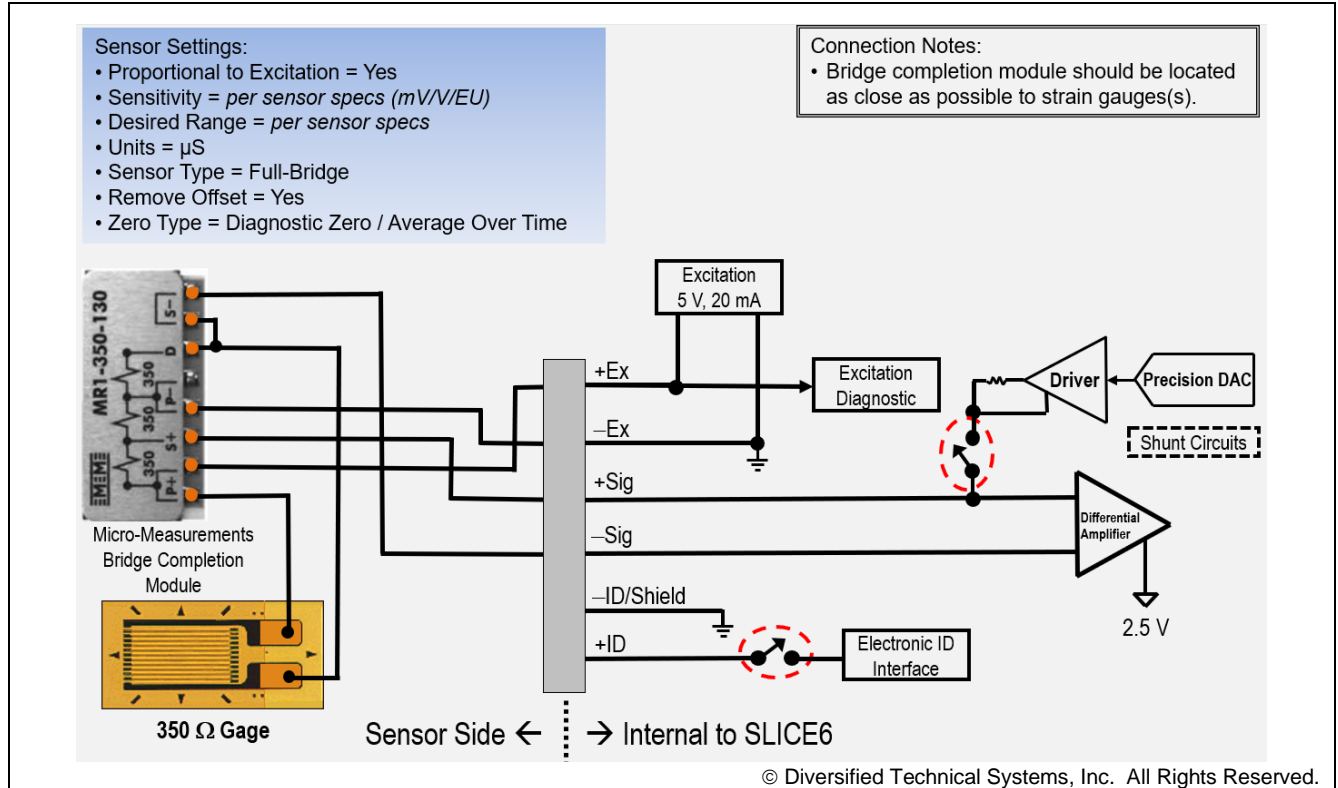

Strain Gage (full bridge)

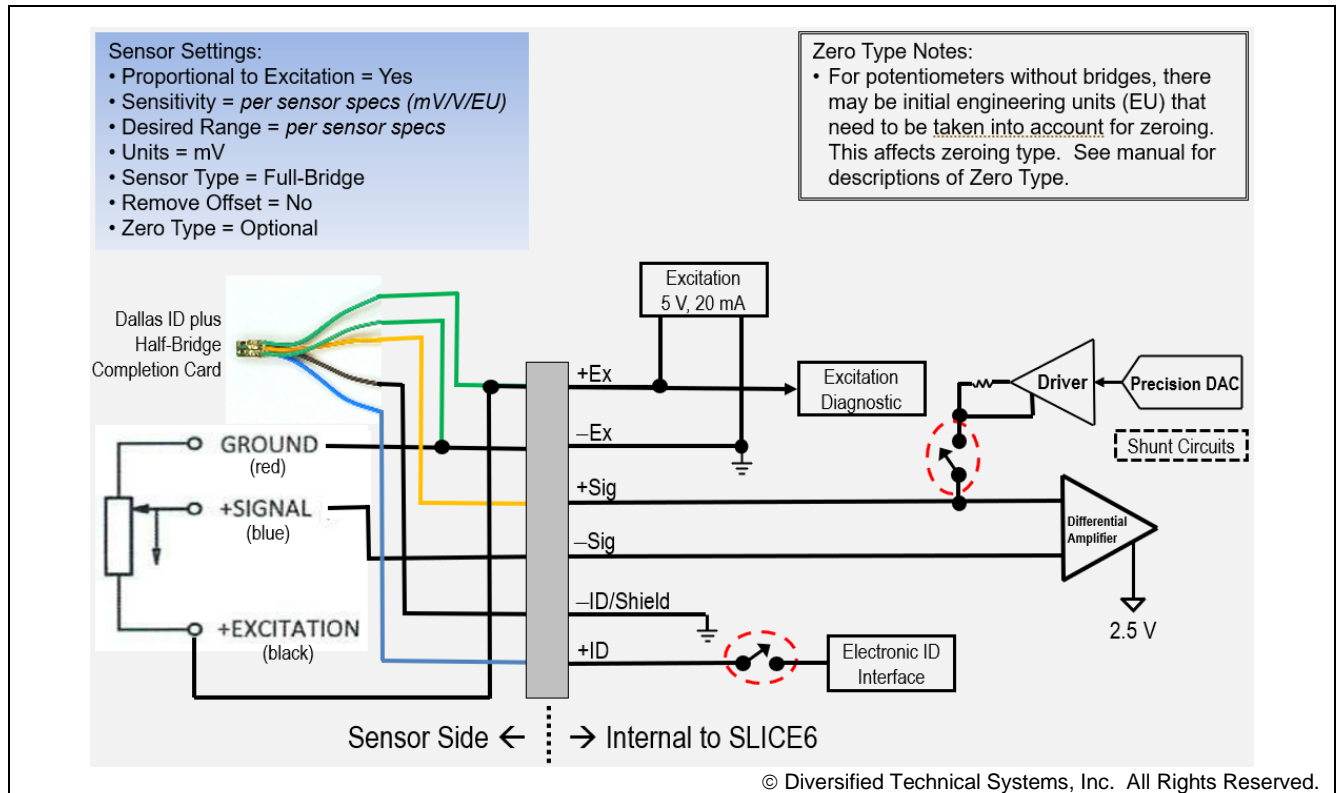

3-Wire Potentiometer

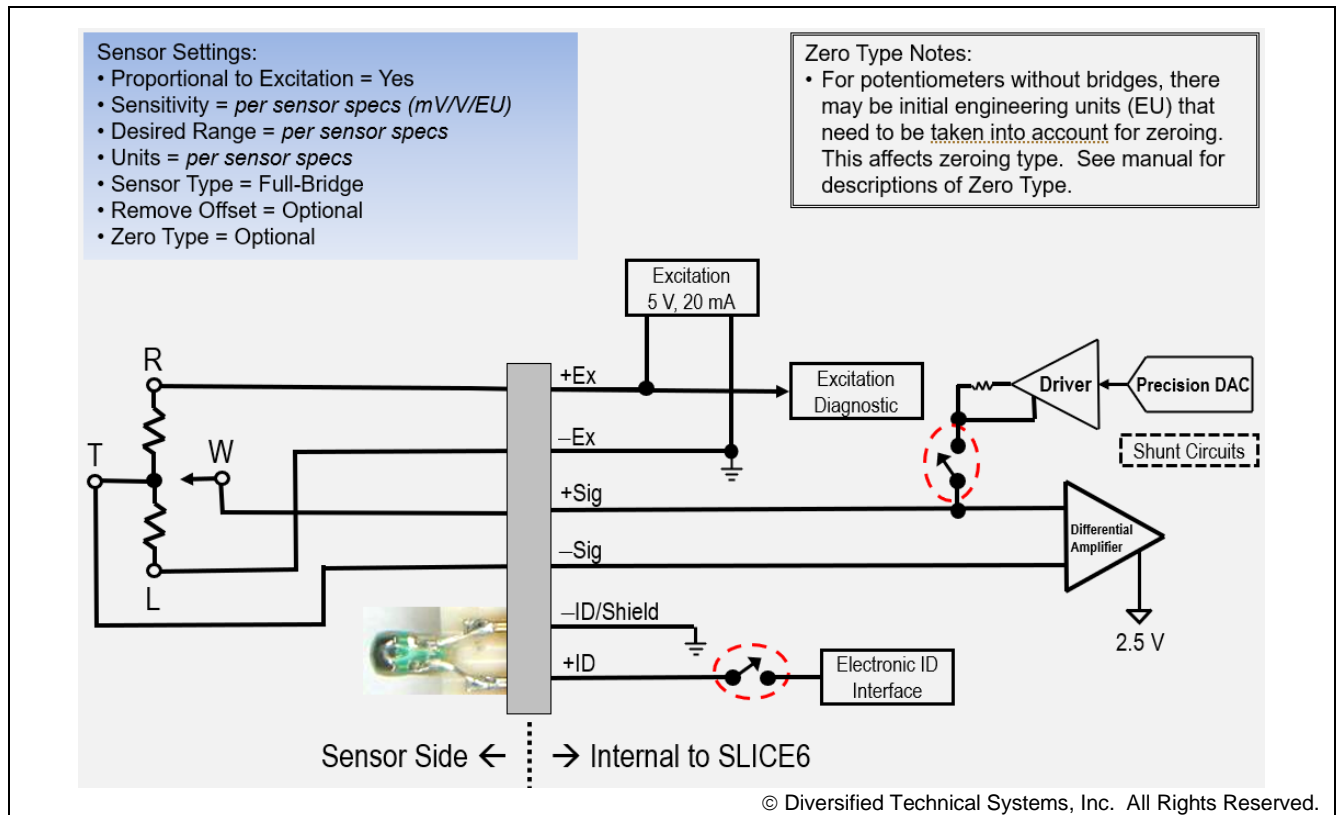

4-Wire Potentiometer

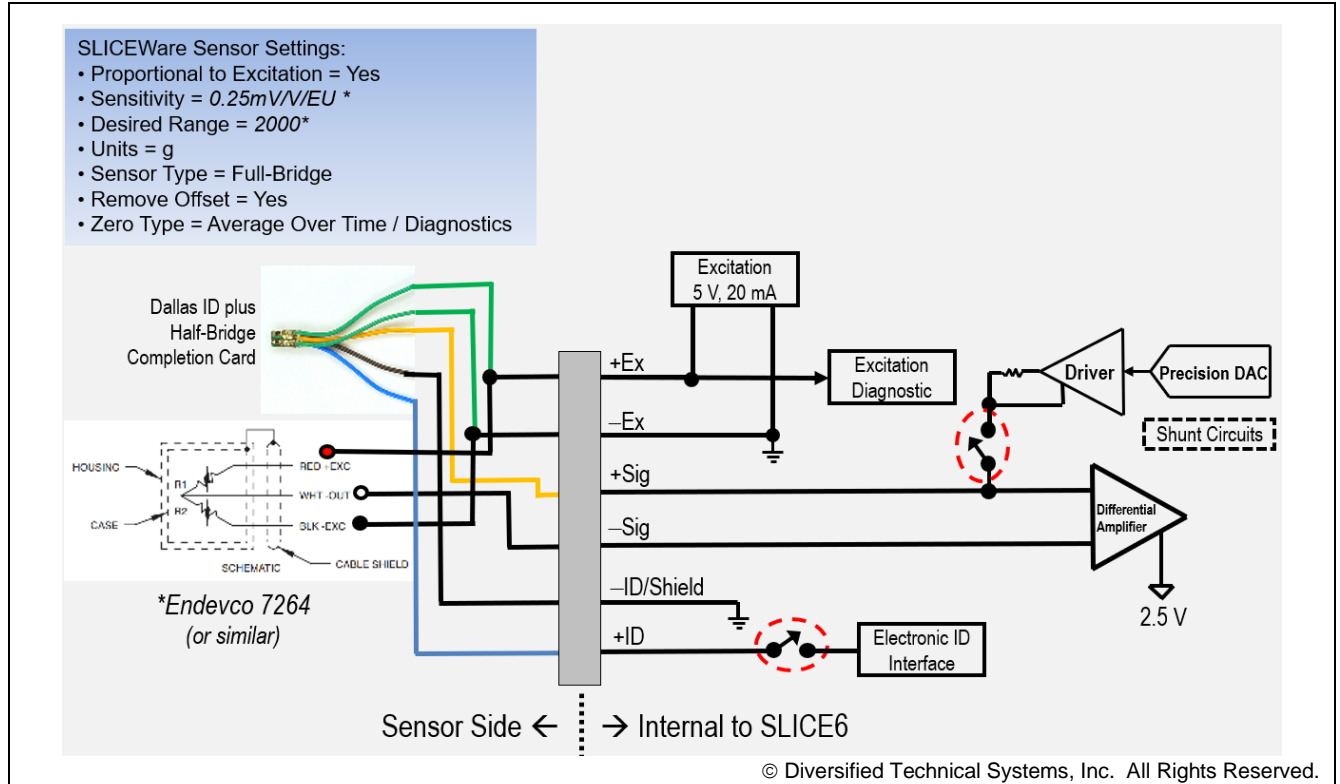

Accelerometer (3-wire)

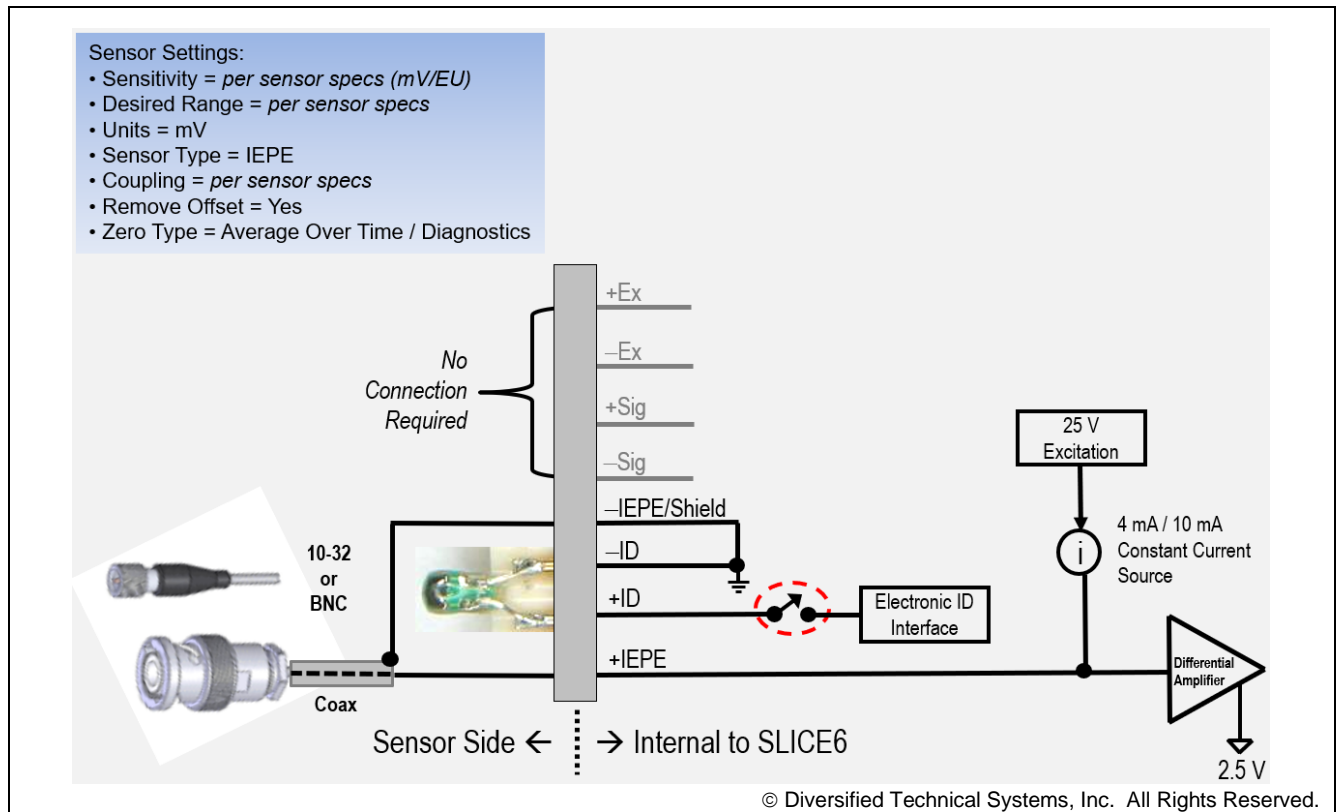

IEPE Accelerometer

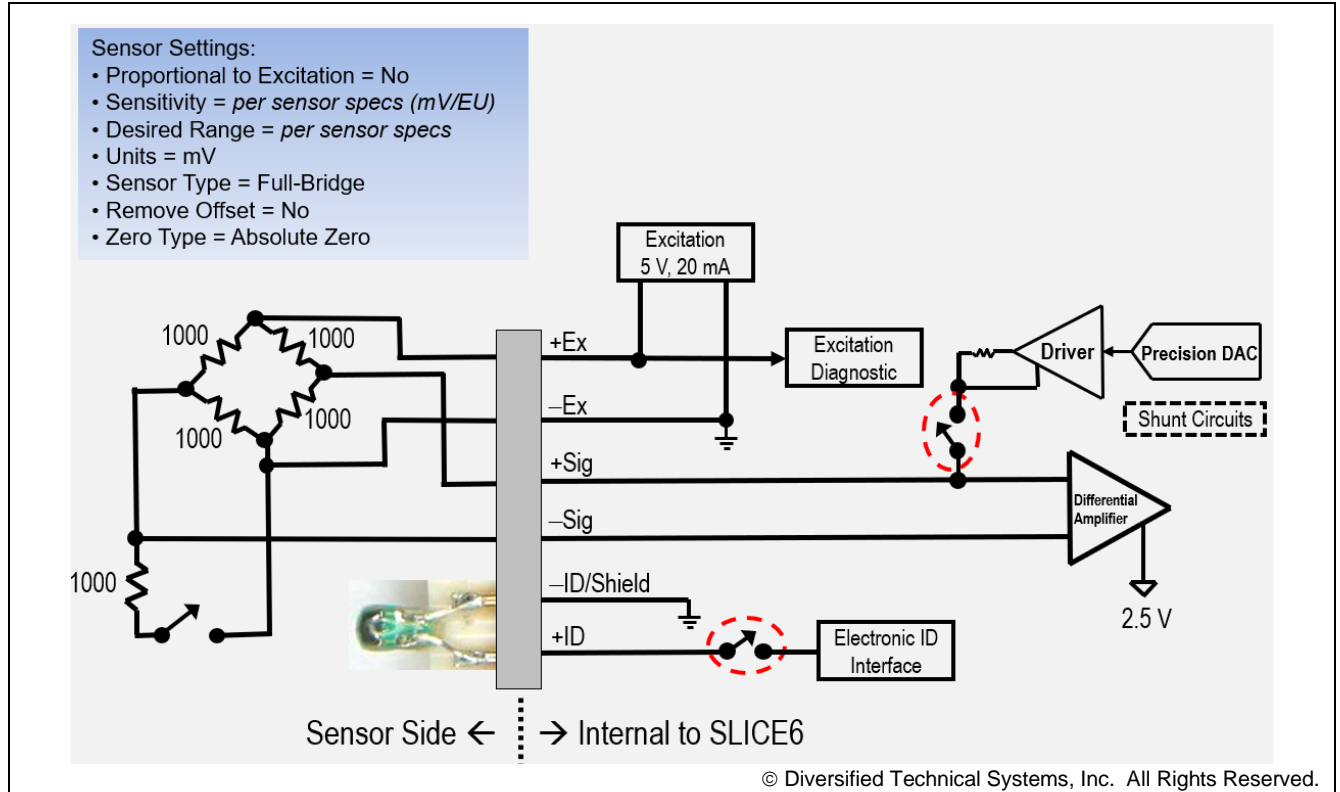

Switch Closure

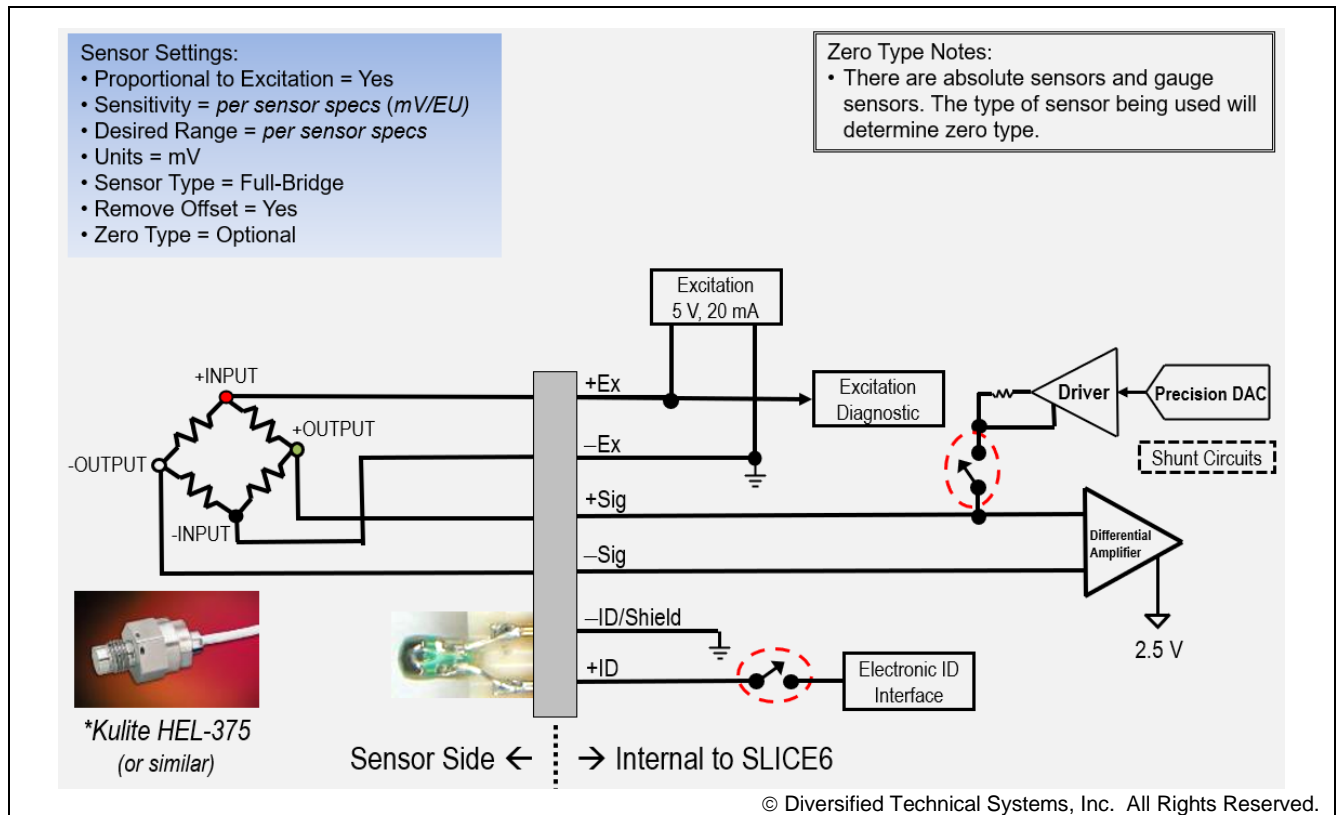

Pressure Sensor

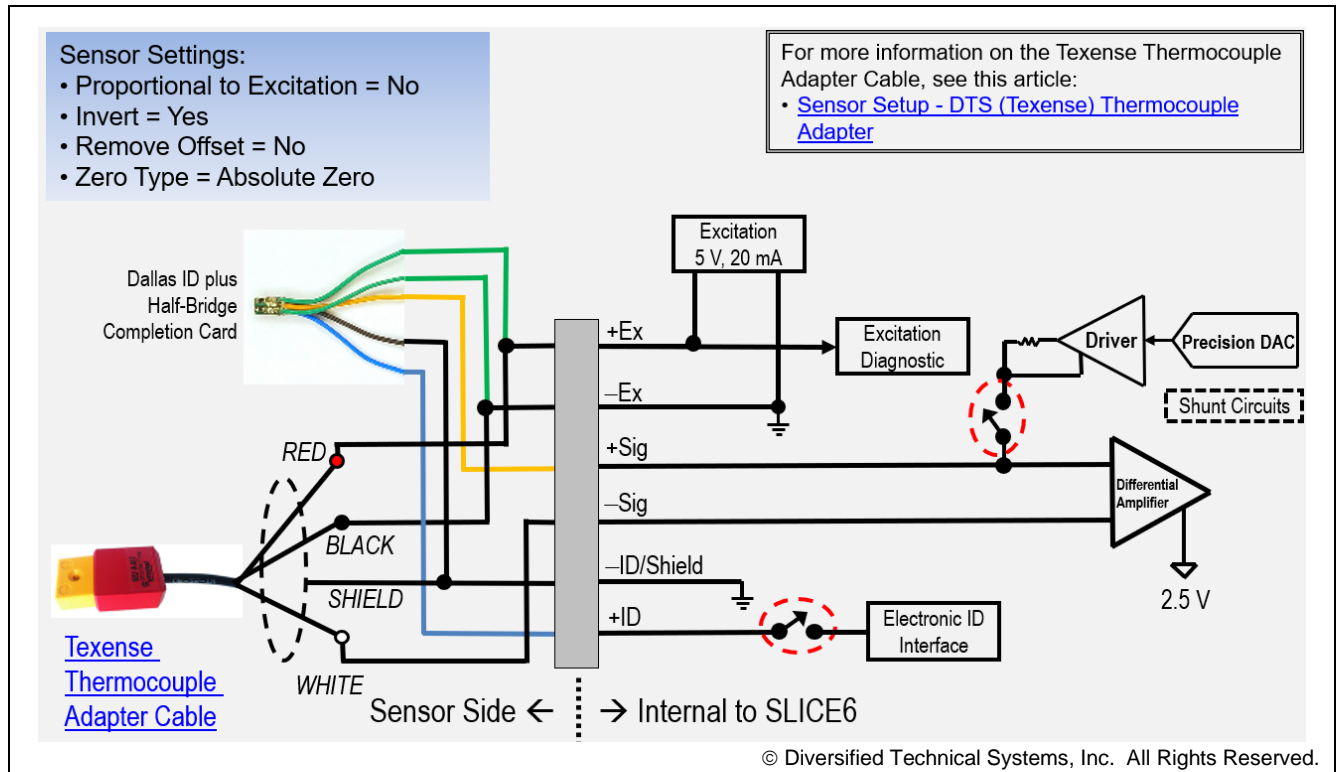

Thermocouple (J and K)

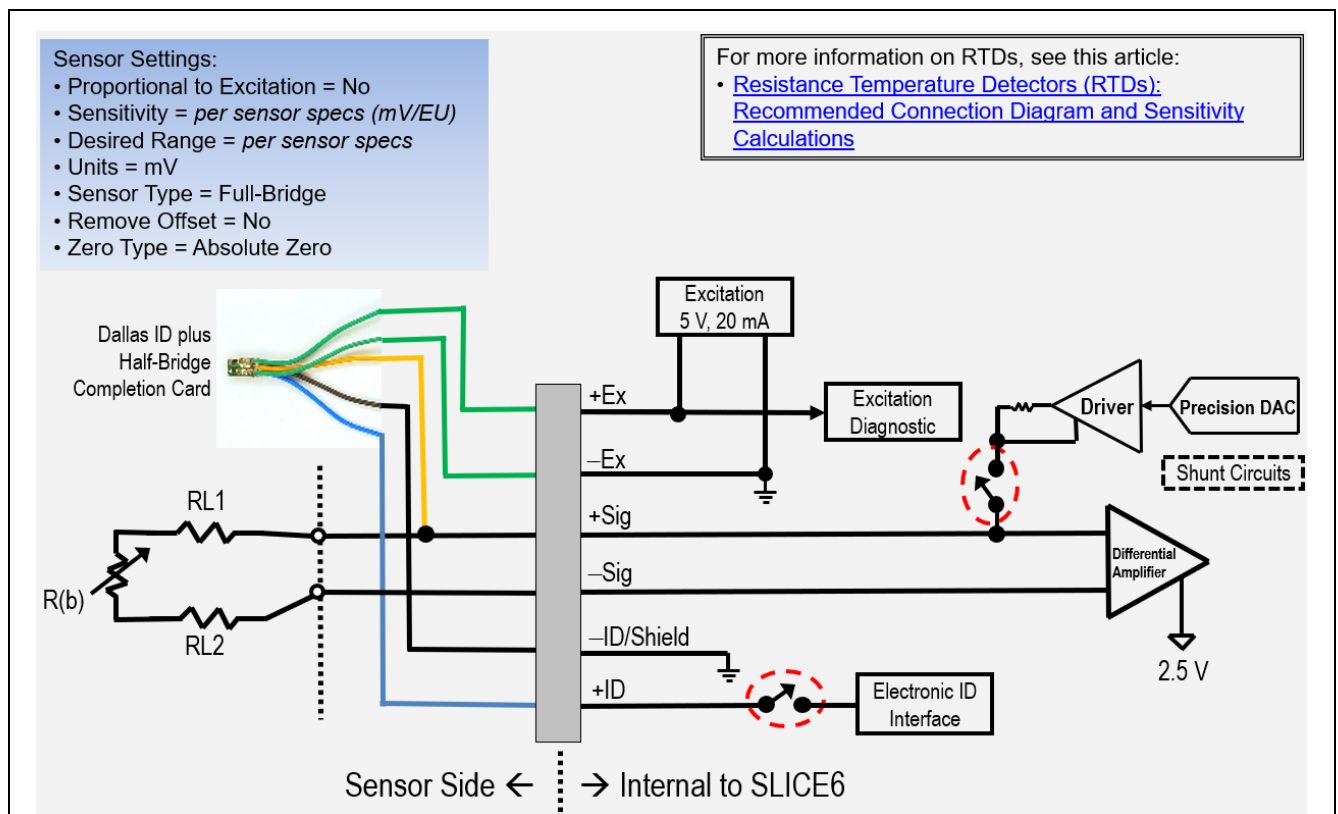

RTD (2-wire)

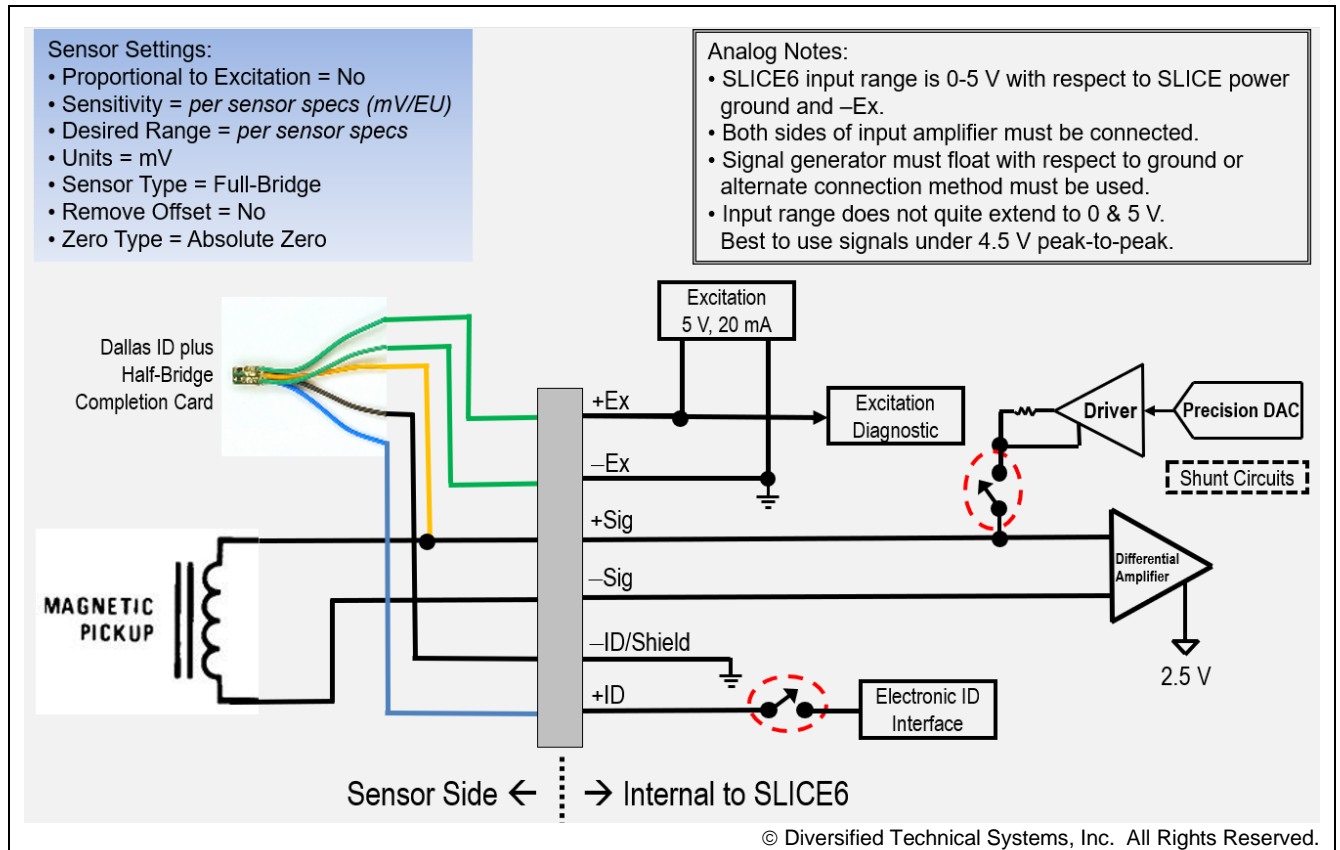

Magnetic Pickup



1720 Apollo Court
Seal Beach, CA 90740 USA
+1 562 493 0158
www.dtsweb.com

DECLARATION OF CE CONFORMITY

Description	Model
Data Acquisition Module	SLICE6 DAS Module
Distribution Unit	SLICE6 Distributor

The undersigned hereby declares that the products listed above, manufactured by Diversified Technical Systems, Inc., Seal Beach, California, USA, conform to the following directive and standards:

Applicable Council Directive: **89/336/EEC – Electromagnetic Compatibility**

Applicable Harmonized Standards: **EN 55022:1998, EN 55024:1998**

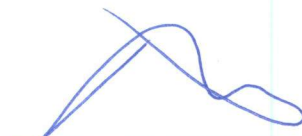

Rollin White
Head of DTS, Senior Director

March 15, 2023
Date

Revision History

Rev	Date	By	Description
0	4 June 2018	EK	Initial release.
1	8 May 2019	EK	Added info on sensor interface connector protector plate. Updated PC specs for DataPRO. Added Hardware Config Specs (Appendix B).
2	15 Mar 2023	E. Kippen	Updated sensor pin assignments (1 and 19 were No Connection). Expanded Appendix C (Sensor Interface Wiring Diagrams).